

# Town of Windsor

## Memorandum

December 13, 2022

\*LATE ITEM\*

**TO:** The Honorable Mayor and Town Council

**FROM:** William G. Saunders, IV, Town Manager

**SUBJECT:** Invoice in excess of \$5,000 – Backhoe Replacement

### Background

The Town of Windsor has been planning to replace an older backhoe, for which parts are getting more difficult to obtain. The old backhoe will be deemed surplus and put up for sale once the new one is received. \$100,000 of the purchase price is budgeted to come from proffers from the Holland Meadows subdivision and the balance is to come from ARPA funds.

### Specifics

The town has received two (2) bids for backhoes. The bids are very similar in that they both represent equipment of brand name, ~100 hp. diesel backhoes with ~80 in. and 24 in. buckets with thumbs.

While the units are similar, there is one notable difference between the two that should be mentioned; the thumb on the Case backhoe is hydraulic, while the thumb on the John Deere is manual. The hydraulic thumb on the John Deere was changed to manual as part of cutting costs in the bids; either type of thumb is acceptable and an improvement over the absence of one, but the hydraulic thumb is more functional.

Both of these bids for backhoes were received through Sourcewell, which is an independent purchasing organization that provides cooperative purchasing contracts, allowing for already-procured pricing without the locality having to host its own solicitations.

### Recommendation

The staff recommends purchase of the 2022 Case 580SN backhoe from Lawrence Equipment.

### Enclosures

Two (2) Backhoe estimates

### Recommended Motion

Recommend approval

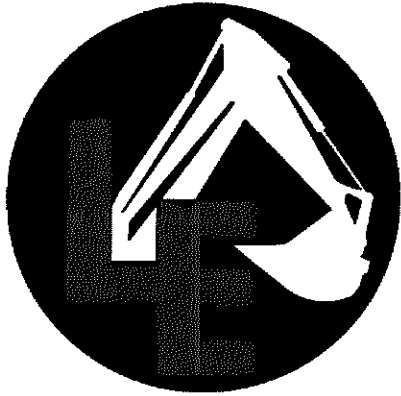

# LAWRENCE

## E Q U I P M E N T

Pearce Barth

11/17/22

Municipal Sales Representative

Lawrence Equipment Richmond

### **2022 Case 580SN**

#### **Options List:**

Enclosed Cab w/ Heat and A/C

82" 4-n-1 Bucket w/ Bolt on Cutting Edge

24in Digging Bucket w/ Hydraulic Thumb

Pilot Controls (Joystick) w/ Powerlift

Front and Rear Lights

Extendahoe w/ Additional Counterweight

Flipover Stabilizer Pads

Mechanical Cloth Seat

Auto Ride Control

Comfort Steer

Case Quick Hitch Coupler

**Pricing:**

Sourcewell List Price: \$184,655.00

Sourcewell Discount: (\$68,322.32)

Sourcewell Price After Discount: \$116,332.65

Freight and PDI: \$2,832.00

**Total Sourcewell Pricing:**

Total Before Discount: \$119,164.65

Lawrence New Customer Discount: (\$3,000.00)

Total Price: \$116,164.65

**Additional Attachments:**

Digga Bucket Broom w/ Water Kit: \$8,900.00



## ENGINE

Model	FPT F5BFL413B
Emissions Certification	Tier 4 Final
Type	Diesel 4-stroke, Turbocharged
Cylinders	4
Bore/Stroke	3.90 x 4.33 in (99 x 110 mm)
Displacement	207 in <sup>3</sup> (3.4 L)
Fuel injection	Direct, high pressure common rail – HPCR
Fuel	Diesel
Engine speeds*	RPM
Rated speed – full load	2200
Low idle	900 – 1000
High idle – no load	2330 – 2430
Horsepower @ 2200 RPM:	
Gross	97 hp (72 kW)
Net	95 hp (71 kW)
Maximum torque @ 1400 RPM:	
Gross	334 lb-ft (453 N-m)
Net	333 lb-ft (452 N-m)
Torque rise at rated speed	45% +/- 5%
Radiator:	
Core type	Square wave
Core size area	486 in <sup>2</sup> (3 145 cm <sup>2</sup> )
Rows of tubes	4
39° fan:	
Style	9 blade suction
Diameter	19.65 in (499 mm)
Ratio**	1.4:1
Pump operating angle ratings:	
Side to side	Rated 35°
Fore and aft	Rated 35°
Oil filtration	Replaceable, full flow cartridge

NOTE: \*Engine speeds w/ standard transmission.  
Meets federal emission regulations.  
\*\*Viscous fan.

## DRIVETRAIN

Transmission – standard:  
4F-4R Power Shuttle Synchromesh Transmission  
manual gear shift, fully synchronized

Specifications below apply to the Power Shuttle  
transmission.

Gear ratios	Forward/Reverse
1st	5.603/4.643
2nd	3.481/2.884
3rd	1.584/1.313
4th	0.793/0.657

Travel speeds – Standard Power Shuttle

Transmission	Forward mph (kph)	Reverse mph (kph)
1st	3.8 (6.1)	4.5 (7.3)
2nd	6.0 (9.7)	7.2 (11.6)
3rd	13.1 (21.1)	15.7 (25.3)
4th	24.6 (39.6)	29.5 (47.5)

Transmission – optional:  
PowerDrive H-Type, 4F-4R hydraulic clutch  
shifting w/ auto shift mode and direct drive

Gear ratios	Forward/Reverse
1st	5.533/4.549
2nd	3.359/2.762
3rd	1.533/1.260
4th	0.811/—

Travel speeds – Optional H-Type PowerDrive

DD Transmission	Forward mph (kph)	Reverse mph (kph)
1st	3.9 (6.2)	4.6 (7.4)
2nd	6.3 (10.1)	7.5 (12.1)
3rd w/ DD Feature Off	13.6 (21.9)	16.4 (26.3)
3rd w/ DD	14.2 (22.8)	17.0 (27.4)
4th w/ DD Feature Off	24.2 (39.0)	29.0 (46.7)
4th w/ DD	25.0 (40.2)	29.8 (48.0)

Torque converter ratio 2.2

Differential-lock:  
On-the-go push-button activation

Front/Rear axle (w/ 4WD 12x16.5 front tires):	
Differential ratio	2.0/2.5
Planetary hub ratio	6.0/6.4
Total reduction ratio	12.0/16.0

Service brakes:  
Individually applied, power assisted,  
hydraulically actuated, maintenance-free,  
self-adjusting, outboard mounted, wet disc,  
2 per side.  
Total disc area 384 in<sup>2</sup> (0.25 m<sup>2</sup>)

Parking brakes Trans Mounted  
spring-applied hydraulic release – SAHR

NOTE: Travel speeds at 2312 engine  
RPM specified: w/ 19.5 L x 24.0 tires.

## ELECTRICAL

Voltage	12 Volts, negative ground
Alternator	160 amp
Dual batteries:	850 cold-cranking amps each
Power plugs – 2	30 amps total

## OPERATOR ENVIRONMENT

ROPS/FOPS certified protective canopy;  
Anti-vandalism cover for dash – w/ canopy  
only; Rear fenders extensions; Coat hook w/  
garment strap; Interior rearview convex mirror;  
Mechanical suspension seat – 180° swivel – Vinyl;  
3 in (76 mm) retractable seat belt; Cup holder/  
storage tray mounted on left-hand fender;  
Right-hand storage compartment w/ lid,  
tilt-steering wheel on cab models.

Gauges:  
Engine water temperature; Converter oil  
temperature; Fuel level; Tachometer/  
hourmeter; DEF level.

Warning lights:  
Air cleaner restriction; Alternator; A/C high  
pressure; Cold start; Engine oil pressure;  
Hydraulic oil filter bypass; Parking brake  
engagement; Low fuel; Water in fuel; Low DEF.

Audible alarms w/ diagnostics:  
Coolant temperature; Engine oil pressure;  
Parking brake engagement; Converter oil  
temperature; Shuttle engagement/seat  
position; Backup alarm; Low DEF.

Horn Dual switched front and rear

## OPERATING WEIGHT

**Configuration 1 – SAE Transport:**

No Operator, Loader Bucket, Cab, AC,  
1,100 lb front counter weight, 2WD, Full of  
Fuel, SAE Carry T4 Final Engine, Pilot Controls,  
11 L – 16 @ 52 psi front tires, 19.5 L – 24  
Rear Tires.

17,810 lb (8 078 kg)

**Configuration 2 – SAE Transport:**

No Operator, 4:1 Loader Bucket, E-hoe, Cab,  
1,100 lb front counter weight, Full of Fuel, SAE  
Carry T4 Final Engine, Pilot Controls, 12 x 16.5  
@ 50 psi front tires, 4WD w/ driveshaft guard,  
19.5 L – 24 @ 30 psi rear tires.

19,750 lb (8 958 kg)

**Add-on weights:**

Cab-over canopy	309 lb (140 kg)
Fabricated stabilizer pads	141 lb (64 kg)
Extendahoe®	286 lb (130 kg)

## HYDRAULICS

<b>Pump:</b> Bosch Rexroth Series 31 Variable Displacement Axial Piston Pump	
<b>Main relief pressure:</b>	
Standard	3,450 +/- 50 psi (238 +/- 3.5 bar)
Power Lift	3,625 +/- 50 psi (250 +/- 3.5 bar)
<b>Filtration:</b> 7-micron, full flow replaceable cartridge on return line, condition indicator light for filter.	
Oil cooler	Heavy-duty
<b>Loader flow @ rated engine RPM:</b> 41 gpm @ 2,340 psi (156.2 L/min @ 161 bar)	
<b>Loader control valve w/ pilot or manual backhoe controls:</b> Two or three-spool closed center sectional control valve. Single lever manual control for lift and tilt functions. The three-spool valve uses a proportional Electro-Hydraulic control for the auxiliary function. The lift lever has a positive hold "Float" position and a "return-to-dig" feature.	
<b>Loader auxiliary hydraulics w/ proportional thumb switch w/ detent on loader control handle:</b> 0 – 41 gpm @ 2,340 psi (0 – 156.2 L/min @ 161 bar)	
<b>Backhoe flow @ rated engine RPM:</b> 41 gpm @ 3,100 psi (156.2 L/min @ 214 bar)	
<b>Manual backhoe control valve:</b> Six-spool monoblock open center control valve w/ seventh and eighth spool bolt-on sections. Features "Pro-Control" which includes custom designed spools for each individual function along w/ "swing cushioning" valve for zero-wag swing control. Basic control valve has an open center parallel circuit for all functions.	

**Pilot backhoe control valve:**  
Six, seven, or eight spool sectional closed center control valve. Features "Pro-Control" which includes custom designed spools for each individual function along w/ "swing cushioning" valve for zero-wag swing control. Basic control valve is closed center, w/ circuits in parallel w/ a post-compensated, flow sharing feature for simultaneous operation of all circuits.

### 1-way flow auxiliary hydraulics:

1-way flow hydraulic valve is equipped w/ an adjustable LS relief valve to control attachment pressure and a 6 position flow control selector for 6 detented, distinct flow settings.

#### Actuation:

- Manual backhoe controls – cab floor pedal
- Pilot controls – left-hand joystick

### 2-way flow auxiliary hydraulics\*:

#### Actuation:

- Activate the 2-way flow switch located on the rear console
- Manual shift – 2-way flow linkage on far right of backhoe tower
- Pilot controls – left-hand joystick.

NOTE: \*Available w/ 1-way/2-way Aux. Hyd. option.

## SERVICE CAPACITIES

Fuel tank	35.0 gal (132.0 L)
DEF tank	3.6 gal (13.5 L)
<b>Hydraulic system:</b>	
Total	125 qt (118.0 L)
w/ Extendahoe®	131 qt (123.6 L)
Reservoir w/ filter	53 qt (50.5 L)
Reservoir w/o filter	55 qt (52.4 L)
<b>Transmission – total system:</b>	
2WD Standard	18 qt (17.0 L)
4WD Standard	21 qt (19.4 L)
4WD PowerDrive H-Type	19 qt (18.0 L)

<b>Standard front axle:</b>	
4WD Differential	8.1 qt (7.7 L)
4WD Planetaries – each	0.5 qt (0.5 L)
<b>Rear axle:</b>	
Differential and planetaries	14.4 qt (13.6 L)
<b>Engine oil w/ filter</b>	
	8.5 qt (8.0 L)
<b>Cooling system:</b>	
w/ heater	19.0 qt (18.0 L)
w/o heater	18.3 qt (17.3 L)
Window washer reservoir	3.0 qt (2.8 L)

## OTHER SPECIFICATIONS

<b>Front tires:</b>	
2WD	11.0 L x 16.0, 10-ply rating
4WD	12.0 L x 16.5, 10-ply rating
4WD	12.5/80 x 18.0 10-ply rating
<b>Rear tires:</b>	
2/4WD	19.5 L x 24.0, 10-ply rating
2/4WD	500/70 R24, 10-ply rating

### Turning radius: Curb to Curb:

<b>2WD:</b>	
Brakes on	10 ft 8 in (3.24 m)
Brakes off	12 ft 4 in (3.76 m)
<b>4WD – engaged*:</b>	
Brakes on	11 ft 4 in (3.45 m)
Brakes off	13 ft 10 in (4.21 m)
<b>4WD – disengaged*:</b>	
Brakes on	11 ft 0 in (3.36 m)
Brakes off	12 ft 3 in (3.72 m)

NOTE: \*Turning radius dimensions curb to curb w/ 12.0 x 16.5 front tires and 19.5 L x 24.0 rear tires.

## LOADER BUCKET SIZES

Type	Width	Weight	Struck	Heaped Capacity
<b>Long Lip Bucket:</b>				
without bolt-on edge	82 in (2.08 m)	864 lb (392 kg)	0.88 yd <sup>3</sup> (0.67 m <sup>3</sup> )	1.03 yd <sup>3</sup> (0.79 m <sup>3</sup> )
with bolt-on edge	93 in (2.36 m)	1,188 lb* (539 kg)	1.10 yd <sup>3</sup> (0.89 m <sup>3</sup> )	1.29 yd <sup>3</sup> (0.99 m <sup>3</sup> )
4 IN 1® Bucket with bolt-on edge	82 in (2.08 m)	1,572 lb* (713 kg)	0.85 yd <sup>3</sup> (0.65 m <sup>3</sup> )	1.04 yd <sup>3</sup> (0.80 m <sup>3</sup> )

NOTE: \*Weight of 4 IN 1® bucket includes edges, cylinders and tube lines.

## BACKHOE BUCKET SIZES

Type	Width	Weight	Heaped Capacity
<b>Universal Buckets</b>			
	12 in (305 mm)	295 lb (134 kg)	3.40 ft <sup>3</sup> (0.10 m <sup>3</sup> )
	18 in (457 mm)	356 lb (162 kg)	5.30 ft <sup>3</sup> (0.15 m <sup>3</sup> )
	24 in (610 mm)	427 lb (194 kg)	7.70 ft <sup>3</sup> (0.22 m <sup>3</sup> )
	30 in (762 mm)	489 lb (222 kg)	10.20 ft <sup>3</sup> (0.29 m <sup>3</sup> )
	36 in (914 mm)	552 lb (251 kg)	12.70 ft <sup>3</sup> (0.36 m <sup>3</sup> )
<b>High Capacity Buckets</b>			
	24 in (610 mm)	447 lb (203 kg)	8.50 ft <sup>3</sup> (0.24 m <sup>3</sup> )
	30 in (762 mm)	502 lb (228 kg)	10.60 ft <sup>3</sup> (0.30 m <sup>3</sup> )

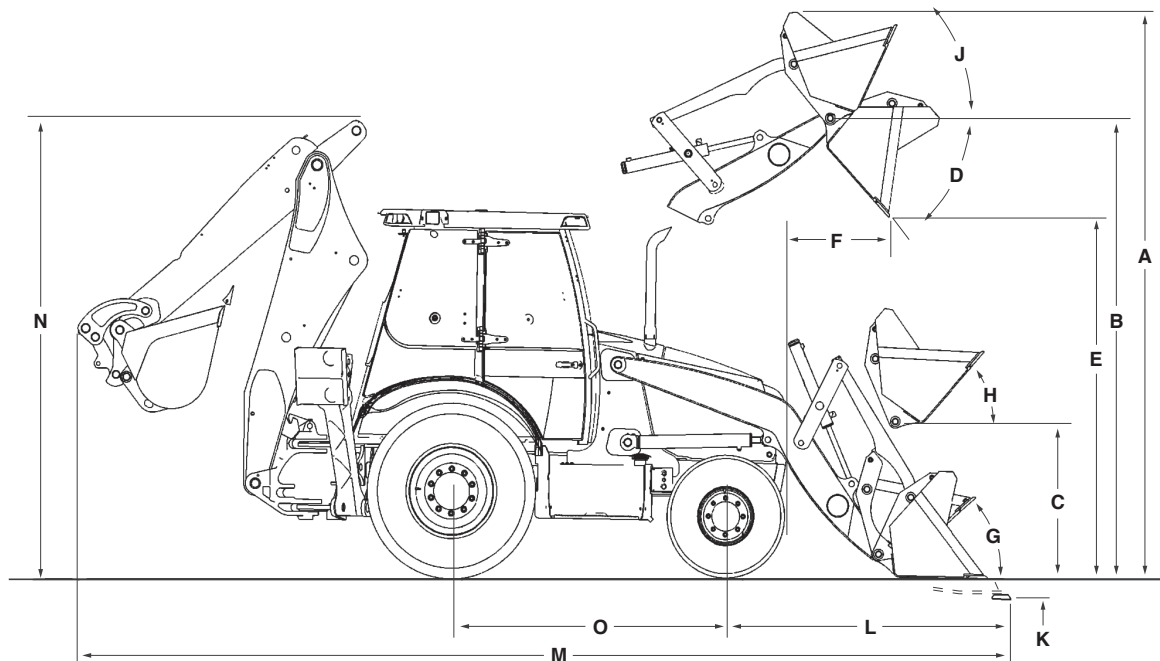

Line drawings are for illustrative purpose only and may not be exact representation of unit.

### LOADER DIMENSIONS

	Long Lip Bucket	4 IN 1® Bucket
<b>A.</b> Overall operating height – fully raised	13 ft 9 in (4.18 m)	13 ft 8 in (4.16 m)
Height to:		
<b>B.</b> Bucket hinge pin fully raised	11 ft 3 in (3.42 m)	11 ft 3 in (3.42 m)
<b>C.</b> Bucket hinge pin at SAE carry	13.6 in (345 mm)	13.6 in (345 mm)
<b>D.</b> Dump angle at full height	47°	47°
<b>E.</b> Dump clearance at full height, 45° dump:		
Bucket	8 ft 10 in (2.69 m)	8 ft 11 in (2.71 m)
Clam open	–	9 ft 8 in (2.96 m)
<b>F.</b> Dump reach at full height, 45° dump – from bumper:		
Bucket	31.5 in (801 mm)	29.1 in (738 mm)
Clam open	–	15.3 in (388 mm)
Bucket rollback:		
<b>G.</b> @ Groundline	42°	42°
<b>H.</b> @ SAE carry	42°	42°
<b>J.</b> @ Full height	Adjustable	Adjustable
<b>K.</b> Digging depth below grade:		
Bucket flat	6.1 in (155 mm)	4.8 in (122 mm)
Clam open – dozing	–	4.1 in (103 mm)
<b>L.</b> Reach from front axle centerline – bucket on ground	6 ft 10 in (2.07 m)	6 ft 8 in (2.03 m)
Lift capacity to full height – calculated values	7,044 lb (3 195 kg)	6,703 lb (3 040 kg)
Breakout force:		
Lift cylinders	9,833 lb (4 460 daN)	9,610 lb (4 359 daN)
Dump cylinders	10,947 lb (4 965 daN)	11,658 lb (5 288 daN)
Bucket cutting edge width	82.5 in (2.09 m)	82.0 in (2.08 m)
Maximum grading angle	114°	114°
Maximum clam opening	–	38.3 in (972 mm)
Moldboard height	–	36.8 in (934 mm)
Raising time to full height – manual/pilot controls	2.6/3.2 sec	2.6/3.2 sec
Bucket dumping time	0.8/1.2 sec	0.8/1.2 sec
Lowering time:		
Power down	1.9/2.1 sec	1.9/2.1 sec
Return-to-dig	2.5/2.2 sec	2.5/2.2 sec
Clam:		
Open time	–	1.1 sec
Close time	–	1.1 sec

NOTE: Loader dimensions taken with 4WD, 12.0 x 16.5 front tires and 19.5 L x 24.0 rear tires.

## DIMENSIONS

	2WD with 17.5 L x 24.0 rear tires	4WD with 19.5 L x 24.0 tires
<b>M. Overall transport length:</b>		
Long Lip bucket with Quick Coupler	23 ft 5 in (7.14 m)	23 ft 4 in (7.10 m)
4 IN 1® bucket with Quick Coupler	23 ft 3 in (7.07 m)	23 ft 1 in (7.04 m)
Long Lip bucket with Straight Links	23 ft 6 in (7.15 m)	23 ft 4 in (7.12 m)
4 IN 1® bucket with Straight Links	23 ft 3 in (7.09 m)	23 ft 2 in (7.06 m)
Overall transport width	7 ft 2 in (2.17 m)	7 ft 2 in (2.17 m)
<b>Height:</b>		
To top of canopy	8 ft 8 in (2.64 m)	8 ft 9 in (2.66 m)
To top of cab	8 ft 9 in (2.68 m)	8 ft 11 in (2.72 m)
To top of exhaust stack	8 ft 5 in (2.58 m)	8 ft 7 in (2.62 m)
<b>N. Transport</b>	10 ft 10 in (3.29 m)	11 ft 1 in (3.37 m)
Ground clearance at backhoe frame	12 in (304 mm)	15.0 in (381 mm)
Angle of departure	15.3°	19.0°
<b>Front wheel tread:</b>		
11.0 L x 16.0	67.5 in (1.72 m)	67.5 in (1.72 m)
12.0 L x 16.5	67.7 in (1.72 m)	67.7 in (1.72 m)
12.5/80 x 18.0	70.3 in (1.79 m)	70.3 in (1.79 m)
19.5 L x 24.0	61.2 in (1.55 m)	61.2 in (1.55 m)
17.5 L x 24.0	63.1 in (1.60 m)	63.1 in (1.60 m)
<b>Width over tires:</b>		
11.0 L x 16.0	79.3 in (2.02 m)	79.3 in (2.02 m)
12.0 L x 16.5	81.1 in (2.06 m)	81.1 in (2.06 m)
12.5/80 x 18.0	82.9 in (2.10 m)	82.9 in (2.10 m)
19.5 L x 24.0	81.4 in (2.07 m)	81.4 in (2.07 m)
17.5 L x 24.0	81.7 in (2.07 m)	81.7 in (2.07 m)
<b>O. Wheelbase:</b>		
19.5 L x 24.0	84.0 in (2.13 m)	84.5 in (2.15 m)
17.5 L x 24.0	84.0 in (2.13 m)	84.5 in (2.15 m)

## CYLINDERS

	Bore Diameter	Rod Diameter	Stroke	Closed Length
<b>Loader:</b>				
Lift – 2	3.25 in (82.6 mm)	1.75 in (44.5 mm)	28.86 in (733.0 mm)	42.95 in (1 062.0 mm)
Dump – 2	3.00 in (76.2 mm)	1.50 in (38.1 mm)	20.33 in (516.5 mm)	29.90 in (759.5 mm)
4 IN 1® clam – 2	3.00 in (76.2 mm)	1.75 in (44.5 mm)	9.08 in (230.6 mm)	19.62 in (498.3 mm)
<b>Backhoe:</b>				
Boom	5.00 in (127.0 mm)	2.50 in (63.5 mm)	38.25 in (971.6 mm)	52.82 in (1 341.6 mm)
Dipperstick	4.75 in (120.7 mm)	2.50 in (63.5 mm)	25.14 in (628.5 mm)	39.65 in (1 007.0 mm)
Bucket	3.50 in (88.9 mm)	2.50 in (63.5 mm)	35.35 in (897.9 mm)	48.17 in (1 223.6 mm)
Extendahoe®	3.00 in (76.2 mm)	1.75 in (44.5 mm)	42.05 in (1 068.0 mm)	56.22 in (1 428.0 mm)
Swing – 2	4.00 in (101.6 mm)	2.00 in (50.8 mm)	11.50 in (292.0 mm)	24.44 in (620.8 mm)
Stabilizer – 2	4.50 in (114.3 mm)	2.25 in (57.2 mm)	21.37 in (542.9 mm)	33.87 in (860.2 mm)

## AXLE RATINGS

	Front – 2WD	Rear	Front – 4WD
Maximum static	70,821 lb (32 124 kg)	90,145 lb (40 889 kg)	64,613 lb (29 308 kg)
Dynamic operating	44,261 lb (20 076 kg)	56,200 lb (25 492 kg)	39,328 lb (17 839 kg)
Static operating	17,704 lb (8 030 kg)	22,480 lb (10 197 kg)	15,732 lb (7 136 kg)
Oscillation – front axle	22° total – 11° side to side	—	22° total – 11° side to side

**BACKHOE LIFT CAPACITIES**

	Standard Backhoe		Extendahoe®			
	Standard	Power Lift	Retracted		Extended	
			Standard	Power Lift	Standard	Power Lift
Boom Lift	Lift Capacity lb (kg)	Lift Capacity lb (kg)	Lift Capacity lb (kg)	Lift Capacity lb (kg)	Lift Capacity lb (kg)	Lift Capacity lb (kg)
+16 ft (4.87 m)	—	—	—	—	2,115 (959)	2,298 (1 043)
+14 ft (4.27 m)	3,039 (1 378)	3,285 (1 490)	2,837 (1 287)	3,083 (1 398)	2,395 (1 086)	2,603 (1 181)
+12 ft (3.66 m)	3,413 (1 548)	3,691 (1 674)	3,201 (1 452)	3,479 (1 578)	2,536 (1 151)	2,757 (1 250)
+10 ft (3.05 m)	3,499 (1 587)	3,784 (1 716)	3,281 (1 488)	3,566 (1 618)	2,593 (1 176)	2,818 (1 278)
+8 ft (2.44 m)	3,485 (1 581)	3,768 (1 709)	3,263 (1 480)	3,546 (1 608)	2,564 (1 163)	2,786 (1 264)
+6 ft (1.83 m)	3,438 (1 559)	3,717 (1 686)	3,213 (1 457)	3,492 (1 584)	2,549 (1 156)	2,770 (1 257)
+4 ft (1.22 m)	3,374 (1 530)	3,648 (1 655)	3,146 (1 427)	3,420 (1 551)	2,521 (1 144)	2,741 (1 243)
+2 ft (0.61 m)	3,307 (1 500)	3,575 (1 622)	3,077 (1 396)	3,345 (1 517)	2,489 (1 129)	2,706 (1 227)
<b>Ground Level</b>	3,251 (1 475)	3,513 (1 594)	3,018 (1 369)	3,280 (1 488)	2,489 (1 129)	2,706 (1 227)
-2 ft (0.61 m)	3,201 (1 452)	3,459 (1 569)	2,965 (1 345)	3,223 (1 462)	2,466 (1 118)	2,680 (1 215)
-4 ft (1.22 m)	3,175 (1 440)	3,430 (1 556)	2,935 (1 331)	3,190 (1 447)	2,446 (1 109)	2,659 (1 206)
-6 ft (1.83 m)	3,182 (1 443)	3,437 (1 559)	2,938 (1 333)	3,193 (1 448)	2,443 (1 108)	2,656 (1 205)
-8 ft (2.44 m)	3,258 (1 478)	3,520 (1 597)	3,007 (1 364)	3,269 (1 483)	2,465 (1 118)	2,679 (1 215)
-10 ft (3.05 m)	3,441 (1 561)	3,717 (1 686)	3,175 (1 440)	3,451 (1 565)	2,530 (1 148)	2,750 (1 248)
-12 ft (3.66 m)	—	—	—	—	2,707 (1 228)	2,943 (1 335)
-14 ft (4.27 m)	—	—	—	—	3,239 (1 469)	3,521 (1 597)
<b>Dipper Lift</b>						
+14 ft (4.27 m)	—	—	—	—	4,281 (1 942)	4,281 (1 942)
+12 ft (3.66 m)	5,822 (2 641)	5,822 (2 641)	5,618 (2 548)	5,618 (2 548)	4,046 (1 835)	4,046 (1 835)
+10 ft (3.05 m)	5,600 (2 540)	5,600 (2 540)	5,399 (2 449)	5,399 (2 449)	3,984 (1 807)	3,984 (1 807)
+8 ft (2.44 m)	5,562 (2 523)	5,562 (2 523)	5,360 (2 431)	5,360 (2 431)	3,913 (1 775)	3,913 (1 775)
+6 ft (1.83 m)	6,236 (2 829)	6,236 (2 829)	6,030 (2 735)	6,030 (2 735)	4,166 (1 889)	4,166 (1 889)
+4 ft (1.22 m)	7,424 (3 368)	7,424 (3 368)	7,203 (3 267)	7,203 (3 267)	4,102 (1 861)	4,102 (1 861)
+2 ft (0.61 m)	—	—	—	—	4,850 (2 200)	4,850 (2 200)

NOTE: Boom and Dipper Lift Capacities are rated per SAE J31 and are 87% of the maximum hydraulic lift force available with the specified options.

**BACKHOE OPERATIONAL DATA**

	Standard Backhoe	Extendahoe®	
		Retracted	Extended
Digging depth:			
Maximum	14 ft 6 in (4.41 m)	14 ft 6 in (4.41 m)	17 ft 11 in (5.47 m)
Maximum with hi-capacity bucket	15 ft 0 in (4.51 m)	15 ft 0 in (4.51 m)	18 ft 6 in (5.63 m)
2 ft (610 mm) flat bottom	14 ft 4 in (4.37 m)	14 ft 4 in (4.37 m)	17 ft 10 in (5.43 m)
8 ft (2.44 m) flat bottom	13 ft 4 in (4.06 m)	13 ft 4 in (4.06 m)	17 ft 1 in (5.19 m)
Overall reach from:			
Rear axle centerline	21 ft 10 in (6.66 m)	21 ft 10 in (6.66 m)	25 ft 3 in (7.69 m)
Swing pivot	18 ft 2 in (5.55 m)	18 ft 2 in (5.55 m)	21 ft 7 in (6.58 m)
Loading height	12 ft 1 in (3.67 m)	12 ft 1 in (3.67 m)	14 ft 5 in (4.38 m)
Loading reach	4 ft 7 in (1.41 m)	4 ft 7 in (1.41 m)	7 ft 3 in (2.20 m)
Swing arc	180°	180°	180°
Bucket rotation:			
Straight links	175.6°	175.6°	175.6°
Mechanical coupler	198.0°	198.0°	198.0°
Hydraulic coupler – Extendahoe® dipper	194.8°	194.8°	194.8°
Hydraulic coupler – standard dipper	198.0°	198.0°	198.0°
Stabilizer spread – operating:			
Flip pad	9 ft 3 in (2.82 m)	9 ft 3 in (2.82 m)	9 ft 3 in (2.82 m)
Cast pad	9 ft 7 in (2.93 m)	9 ft 7 in (2.93 m)	9 ft 7 in (2.93 m)
Digging force:			
Bucket cylinder – SAE rated 3,460 psi	13,975 lb (61 363 N)	13,975 lb (61 363 N)	13,975 lb (61 363 N)
Bucket cylinder – Power Lift	14,452 lb (64 240 N)	14,452 lb (64 240 N)	14,452 lb (64 240 N)
Dipper cylinder – SAE rated 3,460 psi	8,657 lb (38 508 N)	8,657 lb (38 508 N)	6,305 lb (28 045 N)
Dipper cylinder – Power Lift	9,070 lb (40 345 N)	9,070 lb (40 345 N)	6,606 lb (29 382.7 N)
Leveling angle:			
Flip pad	11.8°	11.8°	11.8°
Cast pad	12.8°	12.8°	12.8°

NOTE: Lift capacities apply straight to the rear of prime mover. 4WD with 19.5 L x 24.0 tires equipped with 24 in (610 mm) heavy-duty bucket and Case coupler except as noted.



## STANDARD EQUIPMENT

### OPERATOR ENVIRONMENT

See page 1

### ENGINE

FPT F5BFL413B diesel  
Selective Catalytic Reduction – SCR  
Full flow engine oil filter  
Aspirated air cleaner – replaceable dual element dry type with radial seal  
Fuel filter with water trap  
Radiator with de-aeration bottle  
Antifreeze to -34° F (-37° C)  
Electronic throttles – foot and rotary hand  
Self-adjusting belt  
High Pressure Common Rail computer controlled injection with diagnostic features  
Engine ECO Mode – Detent on backhoe hand throttle, push button switch on dash  
Auto Engine Idle  
Auto Engine Shutdown  
Auto Protection Shutdown  
Electronic Fuel Priming  
Cold Weather Starting Aid:  
Dual 12 volt batteries, glow plugs, engine block heater and heated CCV hose

### DRIVETRAIN

Power Shuttle 4F-4R synchromesh transmission  
Front axle:  
2WD front axle with 11.0 L x 16.0 tires  
4WD mechanically driven front axle with 12.0 L x 16.5 tires and drive shaft guard  
Rear axle:  
2/4WD heavy-duty outboard planetary drive, with 19.5 L x 24.0 tires  
Torque converter – 11.8 in (300 mm)  
On-the-go electric 4WD control  
Electric F/R shuttle control  
Electric differential lock control, push-button  
Park brake, spring-applied, hydraulic release – SAHR  
Drive shaft guard – 4WD models

### HYDRAULICS

Ground level remote hydraulic test ports  
Pump:  
41 gpm @ 3,000 psi  
(156.2 L/min @ 207 bar)  
Heavy-duty hydraulic oil cooler  
7-micron, spin on oil filter

### LOADER

Bucket position indicator; Lifting lugs and tie downs on standard bucket; Single lever control with self-leveling and return-to-dig; Hand operated clutch disconnects on loader and shift levers, single lever 4-function loader control: lift, dump, clutch cut-out, differential lock

### BACKHOE

Over center design, Fabricated “S” boom; Pro Control System; Dipperstick integrated serrated gripper teeth; Case mechanical coupler  
Cleated dirt stabilizer pads

### OTHER

Forward tilt engine hood  
Replaceable, molded front bumpers  
Front/Rear tie downs  
Reflective logos  
Signal Lights – cab and canopy:  
2 rear tail/stop  
2 front flashers/turn  
2 rear flashers/turn  
Working/Driving Lights – cab and canopy:  
Adjustable halogen work lights – 55 W:  
4 front  
2 side – one left, one right  
4 rear  
Master disconnect switch and remote jump-start terminals  
Hydrostatic steering  
Backup alarm  
Vertical spin-on engine oil, fuel and hydraulic filters  
Locking DEF/Fuel covers  
Tool box – bolt-on, step-mounted

### TELEMATICS

CASE SiteWatch™ Telematics – includes hardware and a 3-yr Advanced data subscription

### WARRANTY

1-Year/Unlimited-Hour Full-Coverage Base Limited Warranty  
2-Year/2,000-Hour Extended Engine Warranty

## OPTIONAL EQUIPMENT

### OPERATOR ENVIRONMENT

Speed selectable Auto Ride Control – 4WD models

Comfort Steering with two speed steering pump and 3rd/4th gear cutout

ROPS/FOPS certified protective cab available in LH Door or 2 door with heat, A/C, defroster, door activated dome light, 4 front, 4 rear and 2 adjustable side lights, floor mat, tinted glass, bluetooth radio, front and rear wiper and fender extensions

Deluxe Cab package included on 2-door cabs includes: deluxe interior, viscous fan, pull-down sun visor and 72 dba sound level

Premium multi-color, hand stitched cloth, heated air suspension seat – not for use with ROPS Canopy option

### ENGINE

Severe Cold Weather Starting Aid:  
Synthetic transmission, hydraulic and engine oil – order with cold weather starting aid

### DRIVETRAIN

PowerDrive H-Type transmission, 4F-4R, hydraulic clutch shifting, kick down, transmission disconnect and FNR switch in loader control lever, includes auto shift mode and direct drive

4WD heavy-duty mechanically driven front axle with 12.5/80 x 18.0 tires

### LOADER

Auxiliary hydraulics for loader-mounted equipment with thumb-operated proportional control

Hydraulic front quick coupler

Tool portfolio of additional attachments

Buckets – see page 2

### BACKHOE

1-way Auxiliary backhoe hydraulics for hammers, plate compactors or similar 1-way flow attachments

1-way/2-way Auxiliary backhoe hydraulics for hammers, plate compactors or similar 1-way flow attachments or switch to 2-way flow for thumbs, augers or similar 2-way flow attachments

Extendahoe®

Power Lift

Power Boost

Bolt-on hardened gripper teeth

Two-lever control – backhoe or Extendahoe®

Pilot operated control system:

- Fingertip proportional Electro-Hydraulic stabilizer controls
- Thumb-operated proportional Electro-Hydraulic Extendahoe® control
- Thumb-operated horn button
- Thumb-operated auxiliary hydraulic control
- Infinitely adjustable towers
- In-cab switchable “excavator to backhoe” control pattern change

Flip over stabilizer pads

Hydraulic bucket quick coupler

Universal coupler – CAT/Deere compatible

Buckets – see page 2

Hydraulic thumb – Includes: 2 replaceable, high strength, bolt on tines with two positions for Universal or Hi-Cap buckets – meshes with Bucket teeth on 18 in & 24 in Buckets

### OTHER

Front tires:  
11.0 L x 16.0 or 12.0 L x 16.5  
12.5/80 x 18.0 10-ply includes heavy duty front axle

Rear tires:  
500/70 R24 Michelin or 19.5 L x 24.0

Special paint

LED Working/Driving Light Package:  
4 front  
4 rear  
2 side

Front Fenders

Special Feature Request

CaseCE.com

©2020 CNH Industrial America LLC. All rights reserved. CASE is a trademark registered in the United States and many other countries, owned by or licensed to CNH Industrial N.V., its subsidiaries or affiliates. CNH Industrial Capital is a trademark in the United States and many other countries, owned by or licensed to CNH Industrial N.V., its subsidiaries or affiliates. Printed in U.S.A. Contains 10% post-consumer fiber.

IMPORTANT: CASE Construction Equipment Inc. reserves the right to change these specifications without notice and without incurring any obligation relating to such change. Availability of some models and equipment builds vary according to the country in which the equipment is used. The illustrations and text may include optional equipment and accessories and may not include all standard equipment. Your CASE dealer/distributor will be able to give you details of the products and their specifications available in your area.



CASE Construction Equipment is biodiesel-friendly. NOTE: All engines meet current EPA emissions regulations. All specifications are stated in accordance with SAE Standards or Recommended Practices, where applicable.



Always read the Operator's Manual before operating any equipment. Inspect equipment before using it, and be sure it is operating properly. Follow the product safety signs and use any safety features provided.

Form No. CCE202012580SN  
Replaces Form No. CCE201810580SN

580SN

7 of 7

---

**Quote Summary****Prepared For:**

KENNETH SIMS  
TOWN OF WINDSOR  
KENNETH SIMS  
8 E WINDSOR BLVD  
WINDSOR, VA 23487  
Mobile: 757-510-4660  
ksims@windsor-va.gov

**Prepared By:**

BRETT RABEY  
Coastal Equipment Corp.  
504 S Military Highway  
Virginia Bch, VA 23464  
Phone: 757-424-1900  
brabey@coastalequipment.net

---

**Sourcewell Contract Number: 032119-JDC  
ID# 222411**

**Quote Id:** 27747895  
**Created On:** 07 November 2022  
**Last Modified On:** 07 December 2022  
**Expiration Date:** 30 December 2022

---

<b>Equipment Summary</b>	<b>Selling Price</b>	<b>Qty</b>	<b>Extended</b>
JOHN DEERE 310 P-tier Backhoe Loader	\$ 122,500.00 X	1 =	\$ 122,500.00
<b>Equipment Total</b>			<b>\$ 122,500.00</b>

---

**Quote Summary**

Equipment Total	\$ 122,500.00
SubTotal	\$ 122,500.00
Total	\$ 122,500.00
Down Payment	(0.00)
Rental Applied	(0.00)
<b>Balance Due</b>	<b>\$ 122,500.00</b>

Salesperson : X \_\_\_\_\_

Accepted By : X \_\_\_\_\_

# Selling Equipment



Quote Id: 27747895

Customer: TOWN OF WINDSOR

## JOHN DEERE 310 P-tier Backhoe Loader

**Hours:**
**Stock Number:**

Code	Description	Qty
17B0T	310 P-tier Backhoe Loader	1

### Standard Options - Per Unit

183E	JDLink™	1
0202	United States	1
0259	English	1
0351	Translated Text Labels	1
1003	Cab	1
3005	Powershift Transmission - Mechanical Front Wheel Drive (MFWD) with Limited Slip Differential	1
4006	John Deere PowerTech™ EWL 4.5L (276 cu. in.) Engine Meets Final Tier 4 and Stage IV Emissions	1
5245	Galaxy 19.5L-24 12PR Rear & 12.5/80-18 10PR Front	1
6154	Dual Maintenance Free Batteries With Disconnect, Jump Post, and Engine Block Heater	1
6572	Heavy-Duty Bumper - For Machines without a Front Counterweight	1
6752	Extendible Dipperstick	1
7000	No Auxiliary	1
7026	Mechanical Controls, Two Lever, ISO (Deere)	1
7040	Three-Function Loader Hydraulics, Single Lever	1
7700	Less Coupler	1
7806	24 in. (610 mm.) Wide, Heavy-Duty, 7.5 cu. ft. (0.21 cu. m.) Bucket	1
7856	86 in. (2.18 m.) Wide, 1.25 cu. yd. (0.96 cu. m.) Multi-Purpose Bucket	1
8075	Diagnostic Oil Sampling Ports	1
8096	Premium Mirror Option - Exterior Rear View Mirrors (2) and Front View Mirror (1)	1
8109	Sun Visor	1
8115	MFWD Driveshaft Guard	1
8126	Heavy-Duty Grille Frame	1
8131	Heavy-Duty Stabilizer Pads	1

# Selling Equipment



Quote Id: 27747895

Customer: TOWN OF WINDSOR

8142	LED Light Package	1
8146	Left Side Console Storage with Cup Holders	1
8182	Radio, Bosch Basic Package	1
8207	Seat, Cloth Air-Suspension	1
8226	Strobe Light with Magnetic Mount	1
<b>Dealer Attachments</b>		
	SMV Sign	1
	Manual Thumb	1
	Hang on style Pallet Forks	1
	Manuals	1

## 310 P-tier Backhoe Loader

### 310 P Standard Equipment

#### ENGINE:

John Deere PowerTech™ EWL 4.5L  
turbocharged 4-cylinder engine  
Serpentine belt with automatic belt tensioner  
Vertical spin-on engine oil filter  
Primary and secondary spin-on fuel filter with  
water separator  
Dual safety element dry-type air cleaner with  
evacuator valve  
Vertical curved exhaust stack

#### COOLING SYSTEM:

Engine radiator  
Engine coolant -40 degrees F (-40C)  
Coolant recovery tank with low level indicator  
Cooling fan with fan guard  
Oil-to-water engine oil cooler  
Oil to air hydraulic oil cooler  
Oil to water transmission oil cooler  
Fold-out hinged cooling system  
High ambient temperature engine coolant

#### POWERTRAIN:

Powershift transmission with torque converter  
Vertical spin-on transmission filter  
Single electric transmission control lever  
(forward/neutral/reverse) with integrated gear  
selection & horn  
Electronic transmission controller with on-board  
diagnostics  
Rigid mounted rear axle with 3-planet final drive  
Differential lock, foot switch activated, protection  
on/off  
Mechanical front wheel drive  
Hydrostatic power steering with emergency  
manual mode power-assisted hydraulic service  
brakes inboard, wet disc, self-adjusting and self-  
equalizing (conforms to ISO 3450)  
Power-assisted hydraulic service brakes  
inboard, wet disc, self-adjusting and self-  
equalizing (conforms to ISO 3450)  
Parking/emergency brake: independent of

service brakes (conforms to iso 3450) spring applied, hydraulically released, wet multi-disc

#### HYDRAULICS:

28 GPM (106 L/m) single gear pump - open center

Dedicated hydraulic reservoir

4 micron vertical spin-on filter

"O" ring face seal connectors

Circuit relief valve protection

Economy mode

#### BACKHOE:

14 ft. 4 in. (4.38 m) digging depth (extendible dipperstick, retracted)

Backhoe transport lock lever

Swing locking pin stored in op. station

ISO (Deere) two lever mechanical backhoe controls

Reversible pad stabilizer feet with integrated lock stabilizer two-direction anti-drift valves less bucket with bucket pins

Backhoe boom includes mounting hole for optional boom protection plate.

#### LOADER:

Return-to-dig feature

Bucket level indicator

Hydraulic self-leveling (anti-spill)

Single lever control with electric clutch cut-off switch

Less bucket with bucket pins

Loader boom service lock

High-visibility loader arms

#### ELECTRICAL:

12 volt system

145 amp alternator

(4) front drive/work, (4) rear work and (2) side docking halogen lights (32,500 candlepower each) (2) front and (2) rear turn signal/flashing (4) turn signal/flashing/rear stop tail lights - 2 front and rear

(2) rear reflectors

Single battery with 175 minute reserve capacity and 950 CCA

Blade type multi-fused circuits

By-pass start safety cover on starter  
Positive terminal battery cover

#### OPERATOR STATION:

Modular-design ROPS/FOPS (level 2) canopy  
with molded roof (meets ISO 3471 and ISO  
3449): isolation mounted

Left and right side access

Slip resistant steps and ergonomically located  
handholds (conforms to SAE J185)

Seat, deluxe deep foam, vinyl cover, high back  
with adjustable:

Suspension for weight/height

Fore-aft

Lumbar adjustment

Flip-up arm rests

3 in. orange seat belt with retractor

Fixed steering column

Engine coolant temperature gauge

Fuel gauge

Transmission oil temperature gauge

Electric monitor system with audible and visual  
warning:

- Air cleaner restriction
- Low alternator voltage
- Engine coolant temperature
- Engine oil pressure & temperature
- Hydraulic filter restriction
- Low brake pressure
- Seat belt indicator
- Transmission oil temperature
- Fuel level
- Hourmeter / tachometer / voltmeter

Machine diagnostics

Key start switch with electric fuel shut-off

Horn (1-FNR, 1- side console)

Interior rearview mirror

Rotary hand throttle

Suspended foot throttle

12 volt outlets (1)

Operator's manual storage compartment

Integrated cup holder with form fitting rubber  
insert

Lockable right hand storage

Coat hook



OVERALL VEHICLE:

(2) front and (2) rear built-in tie downs

One piece unitized construction mainframe

Extended grille frame

Front cover

Dent resistant rear fenders

Vandal protection locking for:

Engine hood

Monitor

Tool box

Hydraulic reservoir

34 gal. (128.7 L) fuel tank

Reverse earning alarm

19.5L- 24 in. 12 PR (R4) tubeless rear tires

12 - 16.5 in. 12 PR traction front sure grip lug

tires

Ground level fueling

Remote grease bank for front axle

Removable tool box with padlock hasp

Tilt hood with (2) service positions

JDLINK Ultimate in approved countries